

ZMK40R12SCM Series Hall Current Sensor

Hall current sensor uses Hall effect principle to measure DC, AC, pulse and various irregular waveform currents under the condition that the original and secondary sides are completely isolated.



Feature

- Hall effect measurement principle
- Meet UL94-V0 standard

Advantage

- Easy to install
- Low power consumption
- Wide measuring range
- High precision and good linearity
- Low temperature drift
- Strong anti-interference ability
- Strong overload capability

Application

- AC frequency conversion speed control device
- DC motor driven static converter
- UPS uninterruptible power supply
- SMPS Switched Mode Power Supplies
- Electric welder machine
- Grid monitoring
- Industrial grade

Performance parameter

Electrical parameters

Rated current rms	I _{pn}	200A	400A	800A	1000A	1200A	1500A
Measuring range	I _{pm}	200A	400A	800A	1000A	1200A	1500A
Rated output @I _p @I _p =0	V _o	2.5± (2*I _p /I _{pn})V 2.5V					
Load Resistance	R _L	>2KΩ					
Supply Voltage	U _c	+5V					
Current consumption	I _c	≤15mA					
Insulation voltage	V _d	5kVAC/50Hz/1min					

Dynamic parameter

Precision (@I _{pn} , Ta=25°C)	X _G	<±1.0%					
Linearity (@Ta=25°C)	E _r	<±1.0%FS					
Zero offset voltage (@Ta=25°C, I _p =0)	V _{OE}	<±25mV					
Magnetic offset voltage(I _{pn} >0)	V _{OH}	<±20mV					
Zero temperature drift	TCV _{OE}	<±1.0mV/°C					
Response time	T _r	<5us					
Accurately followed	di/dt	>100A/us					
Frequency bandwidth (@-3dB)	BW	DC~20kHz					

General parameters

Ambient operating temperature	T _a	-40~+85°C					
Ambient storage temperature	T _s	-55~+125°C					
Weight	m	90g					
Case material		PBT G30/G15 UL94-V0 EN50178:1998					
Executive standard		IEC60950-1:2001 SJ20790-2000					

structure

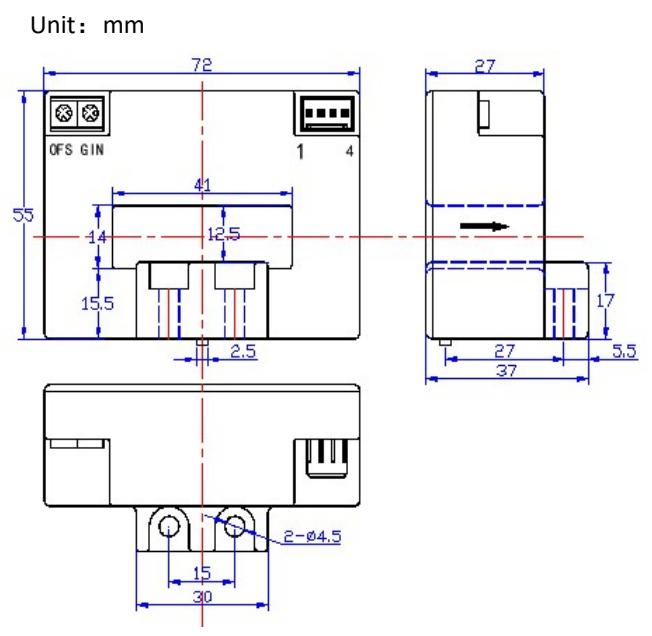

Instructions

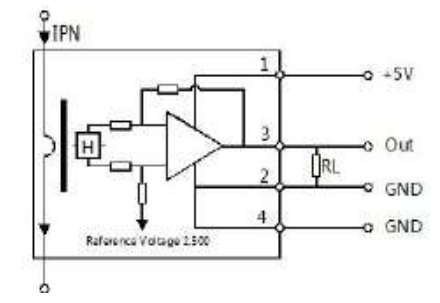

1. The direction of the current should be the same as the direction of the arrow of the casing;
2. Please refer to the wiring definition on the physical shell, the wrong wiring will damaged module;
3. In order to obtain better dynamic characteristics and sensitivity, it is recommended to use a single turn wire and the wire fills the module through the wire hole best;
4. The primary side wire temperature should not exceed 100 °C;
5. The above parameters are standard specifications, and the products can be customized according to customer needs.